



ED 331 e – 8,5mm (1/3") Day/night 3-axis Indoor Dome Camera with IR LED and D-WDR, High Resolution

Features

- High resolution technology (700 TV lines)
- Integrated 2,8~10,5mm DC varifocal lens
- 3-axis mechanism
- Day/night switching with automatically swiveling IR cut filter
- Sony Effio-e platform
- D-WDR functions by SONY ATR technology
- DNR function
- 8 adjustable privacy zones
- Motion detection with 24x16 detection zone blocks
- Black or white casing available
- Optional wall bracket

Technical data

Sensor	8,5mm (1/3") SONY CCD
Picture element	1020 (H) x 596 (V), PAL
Horizontal resolution	700 TV lines
Sensitivity	0,03 lux / F = 1.2 0 lux (IR LED on)
Video output	1,0 Vp-p, 75Ω, BNC
S/N ratio	> 48 dB (AGC off)
IR LED wavelength	850 nm
Recommended object distance	Max. 20 m (depending on reflections in scenery)
Gamma correction	0,45
OSD	Yes, multilingual (German / English / French / Japanese / Russian / Portuguese / Spanish / Simpl. Chinese)
Lens type	2,8 ~ 10,5 mm DC varifocal lens
Day/night control	Automatically swiveling IR cut filter
Back light compensation	On / off
White balance	Auto / indoor / outdoor / manual / push auto
AGC	Yes
Electronic shutter	1:50 ~ 1:100.000
Synchronisation	Internal
DNR	On / off
WDR	D-WDR (Sony ATR) on / off
Mirror	On / off
Motion detection	On / off for 24 x 16 detection zone blocks
Privacy mask	On / off for 8 zones programmable
Colour	Black or white casing available
Power source	12 V DC
Power consumption	max. 340 mA / 4 W
Ambient temperature	-10°C ~ +50°C
Dimensions (Øx H)	111,4 x 83 mm
Weight	450 g

Accessories

BA EHD 2 – wall mount bracket

Material: Aluminium
Colour: White
Dimensions (WxHxD): 150 x 110 x 170 mm
Weight: 600 g
Max. load: 4 kg
Application: with EHD 610 s, EHD 630 s, ED 310 e, ED 331 e



ED331e_db_en_rev03

Dimensions

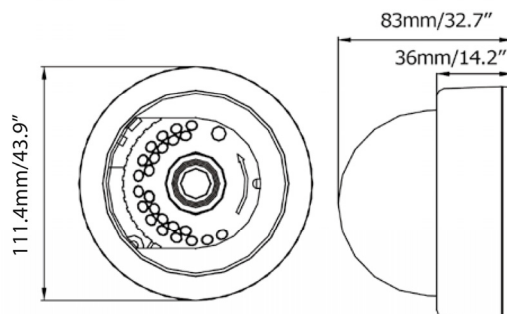

Ordering information

ED 331 e / P-W	8,5mm (1/3") day/night 3-axis indoor dome camera with IR LED and D-WDR, 700 TV lines, 2,8~10,5mm DC varifocal lens, 12 V DC, colour: white
ED 331 e / P-B	8,5mm (1/3") day/night 3-axis indoor dome camera with IR LED and D-WDR, 700 TV lines, 2,8~10,5mm DC varifocal lens, 12 V DC, colour: black
BA EHD 2	Wall mount bracket for EHD 610 s, EHD 630 s, ED 310 e, ED 331 e cameras, aluminium, dimensions (WxHxD): 150 x 110 x 170 mm
AP12A122E0	Power supply, 230 V AC / 12 V DC, 600 mA

ED331e_db_en_rev03